

APPLICATION

- ▶ Suitable for residential or light commercial folding partitions.
- ▶ Leaves can fold to one or both sides of the opening and can be stacked behind a reveal if required.
- ▶ To cover any width of opening, any number of folding units can be used.

DOOR SPECIFICATION

Track System:	Endfold 45	Endfold 75
For Individual Leaves:		
Max Leaf Height	3000mm	3300mm
Max Leaf Weight	45kg	75kg
Max Leaf Width	900mm	900mm
Min Leaf Thickness	35mm	44mm

Folding units of up to eight leaves can be hinged to a post.

A unit with an odd number of leaves, hinged to a post, provides a hinged access door. Alternatively, access should be through either a separate door hinged to a post or a door hinged in one of the folding leaves.

Floating units consist of four, six or eight leaves.

Instruction on leaf width calculation is shown overleaf.

Clearance between leaves to be 2mm minimum.

Door leaves should be constructed to provide secure fitting for the hangers, hinges and guides and can be flush, panelled or glazed.

HARDWARE SPECIFICATION

Track:	180	250
Material	Aluminium	Aluminium
Standard lengths	2000mm, 3000mm, 4000mm and 6000mm.	

Brackets (Face Fix):

Face fitted bracket, 316 stainless	ISS/250	ISS/250
Fit at 900mm maximum centres.		
Fit additional bracket where folding units stack and at the ends of the track.		

Hangers:

End leaves	21GN	21HN
Intermediate leaves	21/4GN	21/4HN

Hangers are fitted with nylon wheels on a sintered bush bearing. Vertical adjustment is simple and positive.

Guide:

With precision bearing	21RB/94	21RB/94
All steel parts to hangers and guides are stainless steel.		

Hinge:

Butt Hinge	404/2	404/3
404/2: 85x60, 404/3: 100x75		

Channels:

Aluminium	94A	94A
Brass	94B	94B
Polypropylene & Alum. Support	94PPA	94PPA
Standard lengths	2000mm, 3000mm, 4000mm and 6000mm	

Drilled and countersunk for screwing to timber floor.

94PA used to provide support 94P channel, 94P not to be used on its own.

Accessories: Flush Pulls and Flush Bolts.

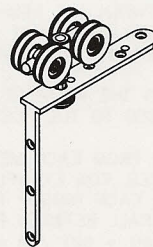
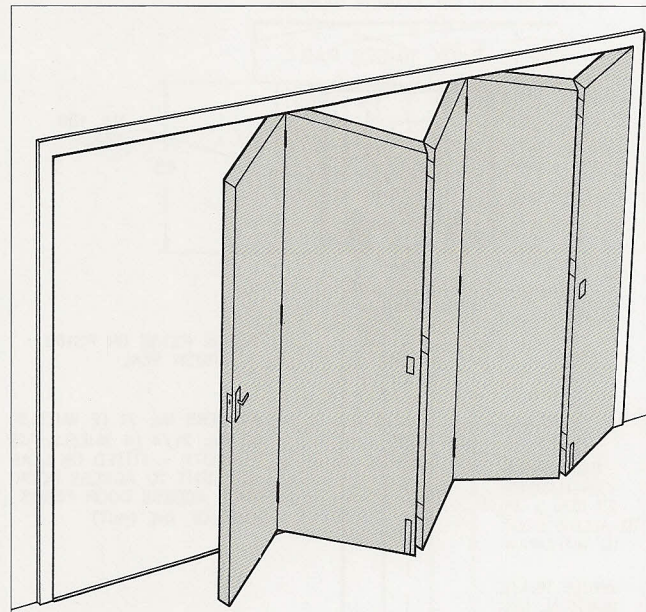

No. 21/4 Hanger

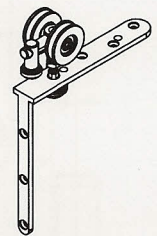

No. 21 Hanger



No. 401 Flush Pull
105 x 41 with 11
mortise

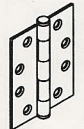

No. 404/3 Butt Hinge
100 x 75



No. 404/2 Butt Hinge
85 x 60

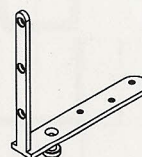

No. 21RB/94 Guide

No. 456 Flush Bolt
190 x 41 with 10
mortise and 45 throw.

Endfold 45 & 75

FOR TOP HUNG INTERIOR FOLDING PARTITIONS, MAX. 75kg EACH LEAF

HENDERSON®

SLIDING & FOLDING DOOR HARDWARE

AUSTRALIA'S WIDEST RANGE

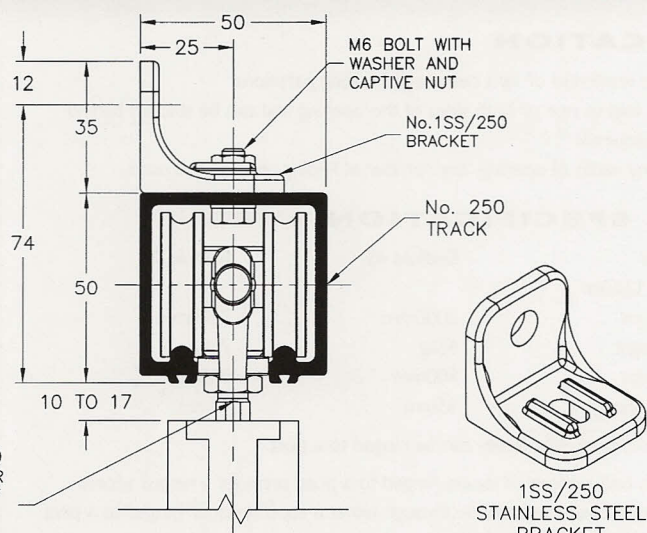
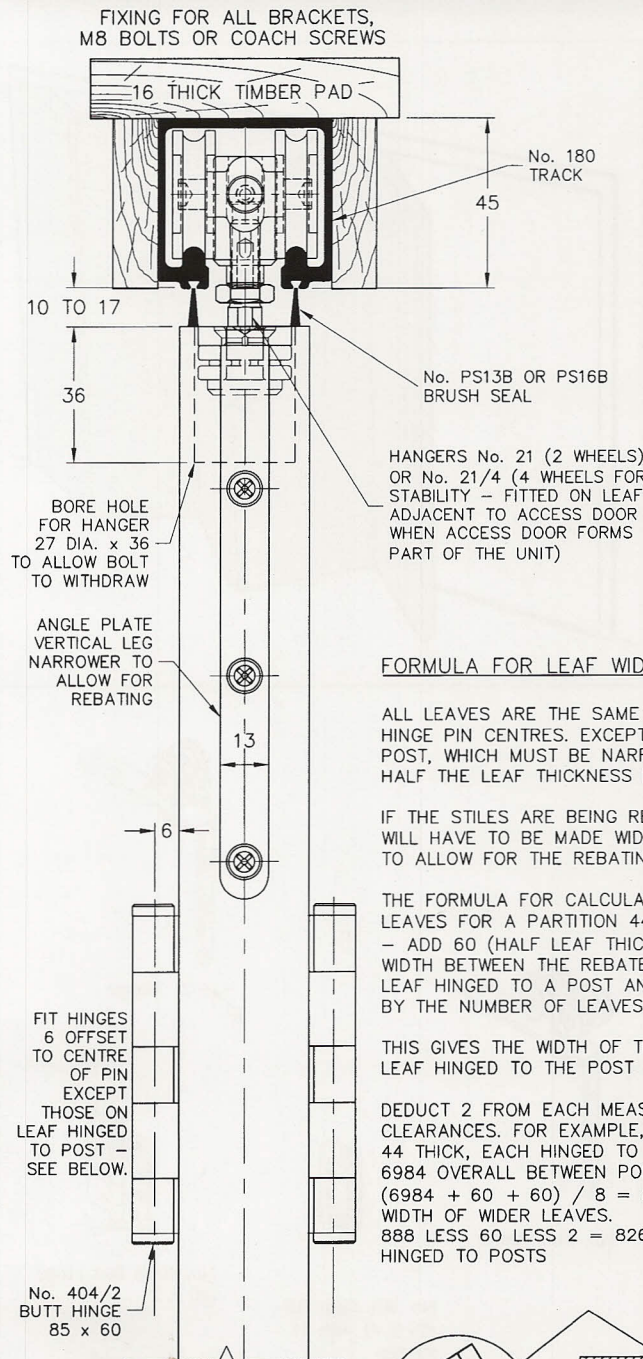

FORMULA FOR LEAF WIDTH CALCULATIONS

ALL LEAVES ARE THE SAME WIDTH, HINGE PIN TO HINGE PIN CENTRES. EXCEPT A LEAF HINGED TO A POST, WHICH MUST BE NARROWER BY THE SUM OF HALF THE LEAF THICKNESS PLUS 38mm.

IF THE STILES ARE BEING REBATED, THE LEAVES WILL HAVE TO BE MADE WIDER THAN CALCULATED TO ALLOW FOR THE REBATING.

THE FORMULA FOR CALCULATING THE WIDTH OF LEAVES FOR A PARTITION 44 THICK IS AS FOLLOWS - ADD 60 (HALF LEAF THICKNESS + 38) TO THE WIDTH BETWEEN THE REBATED POSTS FOR EACH LEAF HINGED TO A POST AND DIVIDE THE RESULT BY THE NUMBER OF LEAVES.

THIS GIVES THE WIDTH OF THE WIDER LEAVES. THE LEAF HINGED TO THE POST IS 60 LESS.

DEDUCT 2 FROM EACH MEASUREMENT FOR CLEARANCES. FOR EXAMPLE, 2 UNITS OF 4 LEAVES 44 THICK, EACH HINGED TO OPPOSITE POSTS, WITH 6984 OVERALL BETWEEN POSTS - $(6984 + 60 + 60) / 8 = 888$ LESS 2 = 886 FOR WIDTH OF WIDER LEAVES. 888 LESS 60 LESS 2 = 826 FOR WIDTH OF LEAVES HINGED TO POSTS

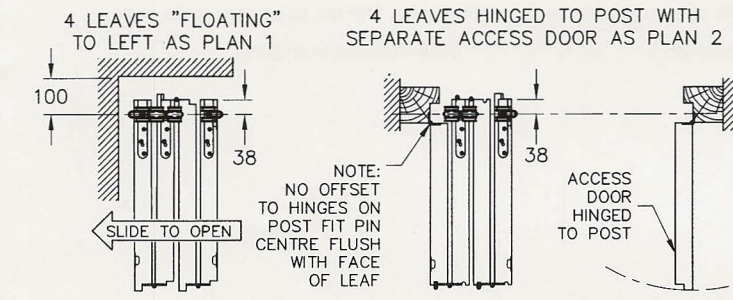
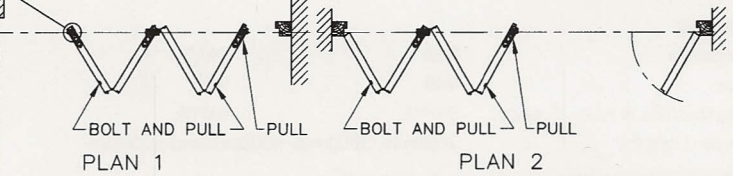
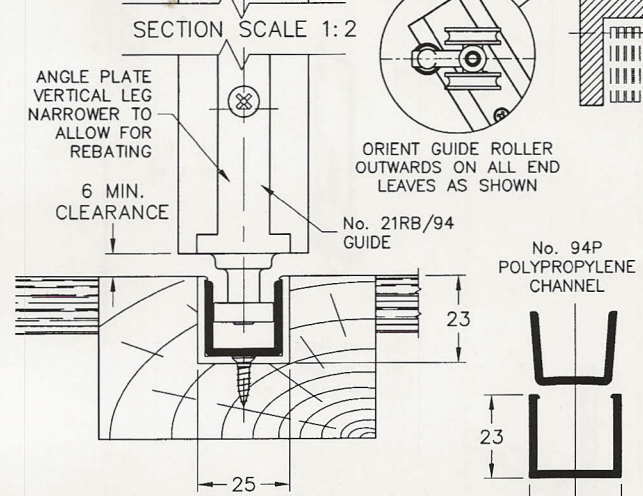
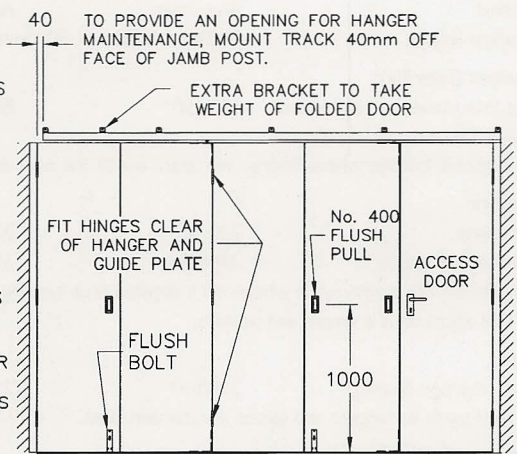
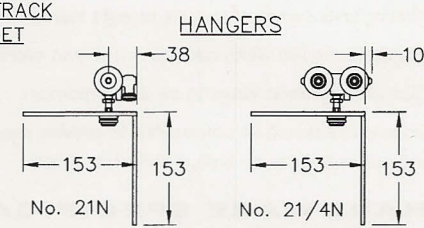

REBATED JOINTS IF REBATING IS PREFERRED IT MUST BE TO LAYOUT ABOVE

TONGUE AND GROOVE JOINTS THESE JOINTS, WITH HARDWOOD TONGUES ARE RECOMMENDED